

AGRICULTURE

INTERCONNECTION OF THE CUTTING DEVICE – A RUBBER THREAD TO THE STEM IN THE PROCESS OF MECHANIZED TEA PLUCKING USING LOW MECHANIZATION TECHNICAL EQUIPMENT

associate Professor *Merab Mamuladze*,
 assistant Professor *Fadiko Abuselidze*,
 associate Professor *Mixeil Lejava*,
 academic Doctor *Rezo Vasadze*

Shota Rustaveli State University

ARTICLE INFO

Received 05 April 2018
 Accepted 23 April 2018
 Published 12 May 2018

KEYWORDS

cutting device,
 rubber finger,
 stem,
 cutting machine,
 tea

ABSTRACT

Tea represents the economy's main field in agriculture and plays a crucial role in growing and cultivation, proper performance and operation of machine technologies. In the areas where small peasant farms and cooperatives have been formed, and operation of heavy-duty machines is inappropriate, the labor costs should be decreased. Therefore, analysis of machines, which allow high tea leaf plucking quality without destroying the inefficient and unnecessary shoots should be refined and become technically perfect. In this scientific research presents interaction of bearing-less cutting machines with a rubber finger with the stem as a working cutting device, this gives opportunities of a lossless and high tea leaf harvesting quality in the small contoured sloped areas by using machines, based on light-duty engines.

© 2018 The Authors.

Introduction. Tea has been the most popular and healthy beverage around the world. Chinese tea industry has stepped into a fast-developing period, with a more and more prosperous production. Nevertheless, the development has been restricted seriously for the underdevelopment of tea plucking machines under the circumstance that Chinese farming population has been reducing since 2000. Nowadays, what badly needs to be solved is the development of tea harvesting mechanization (Suzuki, K. Studies). The later developing ways and gives out some instructive suggestions by analyzing and studying the developing history and present situations of tea plucking mechanization. Japan studied tea plucking machines first around the world. Began with big scissor since 1910, Japan has investigated the small power tea plucking machine, tea pruning machine, self-propelled tea plucking machine, ride-on tea plucking machine successively, all which were reciprocating cutting and air-swept-collecting type (Nakano, T. Influences), such as LU DAO III tea plucking machine, tea plucking machine mount on CHA SHI II tractor and COROLLA tea plucking machine. COROLLA has good travel performance, a neat plucking surface and less lose in tea leaf collecting, for its track chassis ([Lin, X.H. 1989).

The paper presents assumptions which allow determination of energy demand of a machine which uses a simple guillotine cutting of a specific material of low elasticity e.g. soft wood. A simple manner of experimental determination of cutting resistance and a coefficient which characterizes properties of material and a cutting device has been suggested. A numerical value of coefficient was determined based on the principle of maintaining mechanical energy and the principle of labour and mechanical energy balance. Based on the determined coefficient, average load and the power of a cutting unit of a shredder for energy willow were determined (Andrzej A. Stepniewski, Michał Zaremba 2014).

The triangular blade is a primary tool for ultrasonic assisted cutting honeycomb composites. The machining parameters optimization for cutting force minimization, it is proven important for a better surface quality, higher machining efficiency and lower tool wear to be obtained. Based on the analysis of the ultrasonic assisted cutting of honeycomb composites and the triangular blade movement law, the cutting force theoretical model was established. The relationship between the cutting force and the machining parameters was expressed explicitly. The experiments of blade cutting of honeycomb composites with ultrasonic and non- ultrasonic assistance were executed by the control

variable method. The effects of the cutting depth, the blade inclined angle and the deflection angle on the cutting force were verified, which were reflected by the cutting force theoretical model. The theoretical foundation was provided for further optimizing other process parameters during ultrasonic assisted machining, such as both the acoustic and tool structure parameters (X. P. Hu, B. H. Yu, X. Y. Li, N. C. Chen.2017)

Now Russia has realized mechanization of tea harvesting too. England, France, India, Australia, and Argentina have carried out some studies about it separately to various extents (Duara, M. and Mallick, S. 2012) Today, all these countries have, successively, realized mechanization of tea harvesting. In recent years, Japanese scientists have conducted lots of studies on self-propelled tea plucking machine. The most representative one is self-propelled and ride-on type tea plucking machine designed by Terada Seisakusho Co., Ltd., which has a high-clearance track chassis, a cutter flexible-adjusted with its height, and a hydraulic propelling system. With the track driven by a hydraulic system, it could travel flexibly in a complex tea garden. While traveling along the tea rows, it rides on the tea trees (two tracks on the either side of trees) and the cutter move on the top of tea crown. Except moving forward, the cutter has another reciprocating motion of its two blades, which cut the tea leaf off directly. Last, the cut leaves will be collected into mesh bag with air-swept collecting system. This machine liberates the farmer from heavy labors in some extent. A lot of self-propelled tea plucking machines of this type were developed at the same time. And, many patents of tea plucking machine have been granted, such as a kind of tea leaf picking machine (Erada J.C. 2008), crawler-type tea harvesting machine [8], rid-on type tea plucking machine (Aokiha J.A.2011), self-propelled tea plucking machine (Terada, J. 2010) (Zhang, B.C. and Hua, J.2013).

Materials and Methods. The major field of economy in Georgia is represented by the agriculture, therefore, the country's progress and employment of people in the villages depends much on the development of agriculture by implementing mechanization. Accordingly, in the earliest periods, one of the most priority cultures was represented by tea, which was forgotten after the Soviet Union collapse, but in the recent times the state institutions have aimed to restore and rehabilitate the tea culture, though we assume that the capacity that existed in the period of the Soviet Union is not necessary, because it is impossible to restore it concerning the peasant and farming industries simultaneously. For this purpose, it is recommended to invest in stages, and further this may result in a massive development and lead to the revival of the tea culture in our country.

Therefore, for tea plucking purposes, light-duty machine systems should be implemented on slopes or in the small contoured areas. The main work in the machine is performed by the cutting devices, which will be applied to modern agro-technical requirements for a lossless and high tea plucking quality. Recently, great attention is paid to the working cutting devices that perform their work with a method of impulse and are designed so that during the tea plucking a high harvesting quality is carried out without damaging the inefficient stems. For these reasons, it is necessary to determine optimal characteristics. In particular, it is necessary to determine the impact of rubber thread impulse on the tea bush.

In order to determine rubber deformation, we shall use the Hertz Theory related to the deformed stem (Figure 1)

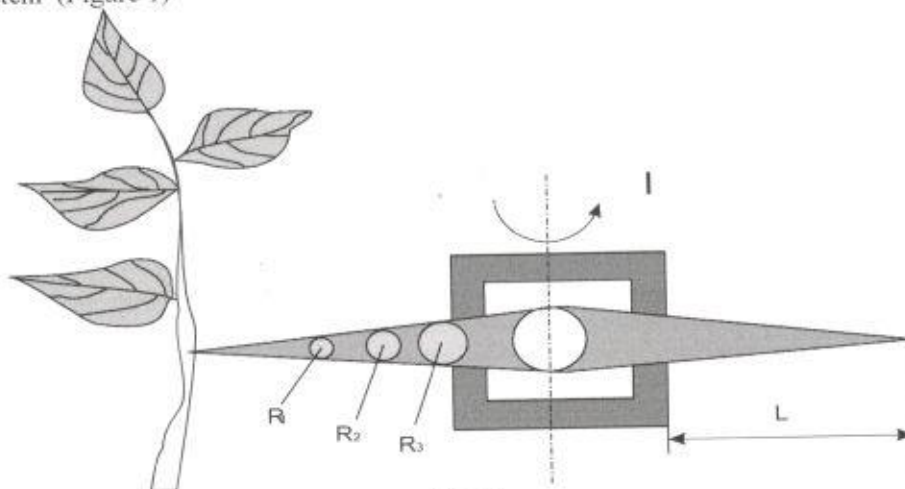

Fig. 1.

According to the Hertz Theory, contact force P is determined by the equation:

$$P = K \cdot a^{\frac{3}{2}} \tag{1}$$

Where a - is a coefficient that depends on the shape and content of the stem.
Based on the well-known researches (Maxaroblidze R. M. 2006) we can express as follows:

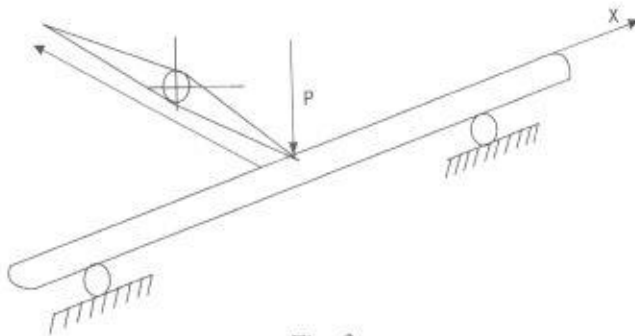

Fig. 2.

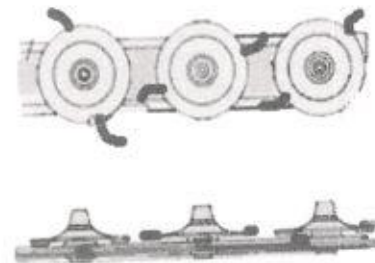

Fig. 3. Small mechanized cutting machine

$$K = \frac{4}{3} \cdot \frac{\pi}{\frac{1-\gamma_1^2}{E_1} + \frac{1+\gamma_1^2}{E_2}} \cdot \frac{q_k}{\sqrt{A+B}} \tag{2}$$

Where γ_1, γ_2 - Poisson coefficients;
 E_1, E_2 - Modules of stem deflection- n/m^2 .
 A and B - coefficients, which depend on geometrical shape of the stem.
 q_k - Coefficient, taken from the tables (Maxaroblidze R.M, Maxaroblidze Z. K.2004).
Deformation Law for the tea stems is defined by using Maxwell differential equation:

$$\sigma + \frac{\mu}{E_2} \cdot \frac{d\sigma}{dt} = \mu \frac{d\varepsilon}{dt} \tag{3}$$

Where σ - tension - n/m^2 ;
 ε - Composite deformation;

t - Time-sec;
 μ - Coefficient of viscosity- $n \cdot \text{sec}/m^2$.
 τ - Relaxation time ($\tau = \frac{\mu}{E_2}$).

From where follows:

$$\sigma = \frac{\mu \frac{d}{dt}}{1 + \tau \frac{d}{dt}} \cdot \varepsilon \tag{4}$$

$$E \rightarrow \frac{\mu \frac{d}{dt}}{1 + \tau \frac{d}{dt}} \tag{5}$$

The impact of rubber thread on the stem may be considered as a rod freely standing on two bearings. Therefore, differential movement of inertia in the center shall be expressed as follows:

$$m = \frac{d^2 S}{dt^2} = -P(t) \tag{6}$$

Where $P(t)$ is a force, derived from the impact of thread on the stem, n .
 m - Stem weight - kg .
 S -finger movement from center, m . and is defined by the equation:

$$s(t) = d(t) + J \left(\frac{1}{2} \cdot t \right) \quad (7)$$

When $t = 0, S = 0, \frac{ds}{dt} = V_0$, where V_0 is the speed of impulse – m/sec.
 (6) Taking into account the formula, we get:

$$\bar{P} = -mp^2 \bar{S} + mpV_0 \quad (8)$$

Taking into account formula (7) we get:

$$\bar{P} = -mp^2((\bar{a} - \bar{J}) + mpV_0) \quad (9)$$

(1) Taking into account the formula, the following expression:

$$(2) \quad \bar{a} = \left(\frac{1}{K} \right)^{\frac{2}{3}} \cdot p^{\frac{2}{3}} \quad (10)$$

Where value of $\frac{1}{K}$ according to formulas (2) and (5) shall be as follows:

$$\frac{1}{K} = \frac{3}{4C\pi} \left(\frac{1-\gamma_1^2}{E_1} + \frac{1-\gamma_2^2}{E_2} \right) + \frac{3}{4C\pi} \cdot \frac{1-\gamma_1^2}{\mu} \cdot \frac{1}{p} \quad (11)$$

Or

$$\frac{1}{K} = \frac{1}{k} + \frac{q}{p} \quad (12)$$

(11) And we introduce notations in the formula (12):

$$C = \frac{qK}{\sqrt{A+B}} \quad (13)$$

$$q = \frac{3}{4C\pi} \cdot \frac{1-\gamma_1^2}{\mu} \quad (14)$$

Taking into consideration p force and J value, we get the following expression (Maxaroblidze R.M. 2006)

$$\bar{J} = \frac{2p \cdot l^3}{EI} \sum_{K=1}^{\infty} \frac{\sin \frac{K\pi\alpha}{l}}{K^4\pi^4 + \delta^2 l^4} \cdot \sin \frac{K\pi x}{l} \quad (15)$$

Where l is a distance between the bearings (Figure 2).

$$\alpha = \frac{l}{2}$$

P is the force impulse point's abscissa –Mm.

$$\delta^2 = \frac{p}{EI} \cdot p^2 \quad (16)$$

According to the well-known researches (Maxaroblidze R.M. 2006).

$$\bar{Y} = \bar{p} \cdot U \quad (17)$$

Therefore, (15) formula may be expressed as follows, taking into account the content of the stem:

$$E_2 \rightarrow \frac{\mu p}{1+\tau p} = E_2 \frac{\tau p}{1+\tau p} \tag{18}$$

If we take into account $x = \frac{l}{2}$, then

$$U = \frac{2}{pl} \sum_{m=1}^{\infty} \frac{1+\tau p}{\tau \cdot p^2 + \lambda^4 p(2m-1)^4} \tag{19}$$

Where $\lambda^4 = \frac{\pi^4}{pl^4} E \cdot l$

If we introduce into formula (9) values of the formula (12) and formula (17) we shall get:

$$\bar{p} = -mP^2 \left[\frac{1}{K^{\frac{2}{3}}} \left(1 + \frac{qK}{P} \right)^{\frac{2}{3}} \cdot P^{-\frac{2}{3}} + UP \right] + mPV_0 \tag{20}$$

According to well-known researches, the equation is elaborated (Maxaroblidze R.M, Maxaroblidze Z. K.2004).

$$p(t) = KV_0^{\frac{2}{3}} \left\{ \frac{t^{\frac{2}{3}}}{\frac{3}{2}l} - \frac{Kq}{\frac{5}{2}l} \cdot t^{\frac{5}{2}} + \frac{K^2q^2}{\frac{7}{2}l} \cdot t^{\frac{7}{2}} - \frac{3KV_0^{\frac{2}{3}}}{2m} \cdot \left(1 + \frac{2m}{\rho l} \right) \cdot \frac{t^4}{4i} + \frac{3KV_0^{\frac{2}{3}}}{2m} \left(2Kq + \frac{4Kqm}{\rho l} \right) \cdot \frac{t^4}{5i} \right\} \tag{21}$$

In order to define the approximate value of impulse, we shall consider impulse in four periods, particularly, the time for the first period of impulse shall be calculated as follows: (Maxaroblidze R.M, Maxaroblidze Z. K.2004)

$$t_1 = \frac{2,705}{K^{\frac{2}{5}}V_0^{\frac{1}{5}} \left(\frac{1}{2m} + \frac{1}{\rho l} \right)^{\frac{2}{5}}} \tag{22}$$

The time of the second period of impulse:

$$t_2 = \frac{2,705}{K^{\frac{2}{5}}V_0^{\frac{1}{5}} \left(\frac{1}{2m} + \frac{1}{\rho l} \right)^{\frac{2}{5}}} \left[1 + 0,821 \frac{qK^{\frac{3}{5}}}{V_0^{\frac{1}{5}} \left(\frac{1}{2m} + \frac{1}{\rho l} \right)^{\frac{2}{5}}} \right]^{\frac{2}{3}} \tag{23}$$

(21) By differentiation of the first and the second parts of the formula:

$$t_{1max} = \frac{1,38555(\rho \cdot l)^{\frac{2}{5}}}{K^{\frac{2}{5}}V_0^{\frac{1}{5}} \left(\frac{1}{2m} + \frac{1}{\rho l} \right)^{\frac{2}{5}}} \tag{24}$$

Taking into consideration the formula (24), we get the maximum value of impulse:

$$P_{max} = KV_0^{\frac{2}{3}} \left\{ \frac{0,765}{K^{\frac{3}{5}}V_0^{\frac{3}{5}} \left(\frac{1}{2m} + \frac{1}{\rho l} \right)^{\frac{3}{5}} \cdot V_0^{\frac{1}{2}} \left(\frac{1}{2m} + \frac{1}{\rho l} \right)} \right\} \tag{25}$$

It is known, that the length of a rubber thread is calculated as follows:

$$l = \lambda \cdot i \tag{26}$$

Where, i - is a radius of inertia:

$$i = \sqrt{\frac{I}{F}} \tag{27}$$

According to (26) and (27) imageries, critical tension of the thread is:

$$\lambda_{kr} = \frac{l}{ni} = \sqrt{2} \cdot l \cdot \sqrt{\frac{p_e \cdot F}{p_{max} \cdot l}} \quad (28)$$

Where: p_e is a critical Euler force., then

$$L_{kr} = \pi \sqrt{2} \cdot \sqrt{\frac{E_1 I}{\rho_{max}}} = \lambda_{kr} \quad (29)$$

Based on experiments and measurements:

Average diameter of a stem $d = 0,002$ m;

Average weight $m_i = 0,0005$ kg

Module of stem deflection $E_2 = 16,6 \cdot 10^6$;

Radius of a rubber thread $R = 0,001$ m;

Module of rubber deflection $E_1 = 0,9 \cdot 10^6$ n/m²;

Rotational Inertia = $0,1 \cdot 10^{-12}$;

Poisson coefficient $\gamma_1 = 0,4$, and $\gamma_2 = 0,4$.

And by conversion of formula (22) we get an expression:

$$t_2 = \frac{2,705(\rho \cdot l)^{\frac{2}{5}}}{K^{\frac{2}{5}} V_0^{\frac{1}{5}}} \left[1 + 0,821 \frac{q K^{\frac{2}{3}} (\rho \cdot l)^{\frac{2}{3}}}{V_0^{\frac{1}{3}}} \right]^{\frac{2}{3}} \quad (30)$$

$$K = \frac{4}{3} \cdot \frac{\pi}{\frac{1-\gamma_1^2}{E_1} + \frac{1+\gamma_2^2}{E_2}} \cdot \frac{q_K}{\sqrt{\frac{1}{2R_1} + \frac{1}{2R_2}}} = \frac{4}{3} \cdot \frac{3,14}{\frac{1-0,4^2}{0,9 \cdot 10^6} + \frac{1-0,4^2}{16,6 \cdot 10^6}} X \frac{0,318}{\sqrt{\frac{1}{2 \cdot 0,0011} + \frac{1}{2 \cdot 0,001}}} = 5,2 \cdot 10^4 \text{ n/m}^{\frac{3}{2}}$$

The value of time relaxations is established by the experiments (Maxaroblidze R.M. 2006) $\tau = 0,01$ sec then the coefficient of viscosity shall be:

$$\mu = E_2 \tau = 0,16 \cdot 10^6 \text{ n. sec/m}^2.$$

By adding a notation into formulas (13) and (14) we get:

$$C = 0,01 \text{ m}^{\frac{1}{2}}; \quad q = 120,2 \cdot 10^{-6} \text{ m}^{\frac{2}{3}} \text{ m/n. sec.}$$

(30) By adding a notation into the formula we get:

$$t_2 = \frac{2,705 \cdot 0,0005^{\frac{2}{5}}}{(5 \cdot 10^4)^{\frac{2}{5}} \cdot 1,07^{\frac{1}{5}}} \left[1 + 0,8 \frac{120,2 \cdot 10^{-6} (5 \cdot 10^4)^{\frac{2}{3}} \cdot 0,0005^{\frac{2}{3}}}{1,07^{\frac{1}{3}}} \right]^{\frac{2}{3}} = 0,0018 \text{ sec.}$$

(25) By adding a notation into the formula we get:

$$P_{max} = 0,538 \text{ n}$$

Rotational inertia for a rubber thread is $I = 0,1 \cdot 10^{-12} \text{ m}^4$.

Afterwards, by adding the notation in the formula (29) we get:

$$L_{kr} = \frac{3,14 \sqrt{0,9 \cdot 10^6 \cdot 0,1 \cdot 10^{-12}}}{0,538} = 0,09 \text{ m}$$

Summary. Therefore, based on theoretical calculations, for the cutting devices of tea plucking machines, where the cutting process is performed by the rubber or metal thread instead of the segmental metal blade, the optimal characteristics values have been established, in particular – the maximum force of rubber thread impulse, length, and value of inertia. It is likely to achieve a fast and high tea harvesting quality and a significant reduction of labor by optimization of the mentioned characteristics in the plucking machines, where a rubber or metal thread is installed on the rotational type cutting machine.

REFERENCES

1. Suzuki, K. Studies on the Wide Application of the Self-Propelled Plucking Machine. *Tea Research Journal*, 45, 63-72. <http://dx.doi.org/10.5979/cha.1977.63>
2. Nakano, T. Influences of Plucking Position on Yield and Quality of Tea in Mechanically-Plucked Tea Bush. *Tea Research Journal*, 86, 11-17. <http://dx.doi.org/10.5979/cha.1998.11>
3. Lin, X. H. (1989) Only Realized Mechanization of Tea-Leaf Picking, *Can Tea Producing Industry Developed*. *Fu Jian Tea*, (1989) 15, 4-7.
4. Andrzej A. Stepniewski, Michał Zaremba- Experimental And Theoretical Method Of Determination Of Loads For Cutting Units. *Scientific quarterly journal ISSN 1429-7264*. 2014. <http://ir.ptir.org>
5. X. P. Hu, B. H. Yu, X. Y. Li, N. C. Chen- Research on Cutting Force Model of Triangular Blade for Ultrasonic Assisted Cutting Honeycomb Composites, *Cirp Conference on Composite Materials Parts Manufacturing, cirp-ccmpm2017*. <https://www.sciencedirect.com/science/article/pii/S2212827117304717>
6. Duara, M. and Mallick, S. Tea Industry in Assam (India): Issues of Migration and Gender Discrimination. *Proceedings of International Conference on History and Society Development (ICHSD2012)*, Bangkok, 24 November 2012, 174-177.
7. Erada, J. C. Traveling Type Tea Plucking Machine. JP Patent No. 2008301831. (2008).
8. Aokiha, J. A. Tea Leaf-Picking Machine. JP Patent No. 2011193754. (2011)
9. Terada, J. and Aoyama, T. Aeling Tea Leaf Plucking Machine. JP Patent No. 2010057421. (2010)
10. Terada, J. Raveling Type Tea-Leaf Plucking Machine for Sweeping Dew. JP Patent No. 2010148519. (2010)
11. Zhang, B. C. and Hua, J. Tea Machine Base, Control Method Thereof and Tea Machine. US Patent No. 2013059049. (2013)
12. Maxaroblidze R. M - Methods of impact theory and rheology of agricultural mechanics Tbilisi. 2006.
13. Maxaroblidze R. M, Maxaroblidze Z. K. - Substantiation of the critical speed of non-cutting cutting of plant materials. Tbilisi 2004.